

8

7

6

5

4

3

2

1

BILL OF MATERIALS

| MTL | PART | DESCRIPTION | QTY | UOM |
|-----|-----------|---|-----|-----|
| 10 | 92210A550 | Hex Drive Flat Head Screw - 1/4" - 20 Thread Size, 2" Long | 3 | EA |
| 20 | 3112T310 | Zintra Gripper Hanging Kit Containing Barrel, Wire Adjuster and Wire Loop | 3 | EA |
| 30 | 1210-0107 | 1.50 OD x 0.0625 x 20-FT TUBE, 6063-T4-S, CLEAR ANODIZED | 2 | LEN |

REVISIONS HISTORY

| REVISION | DESCRIPTION | DATE | APPROVER | ISSUED |
|----------|---------------|-----------|----------|--------|
| A | Stratus Cloud | 9/11/2017 | Approver | RJR |

FUNCTION: TO PROVIDE VISUAL PLEASURE AND ACOUSTICAL DAMPING

NOTES

Original design concepts are protected under Federal Copyright Laws and are the property of Rainier Industries, Ltd. Any reproduction of this design concept without written consent is expressly forbidden.

ASSEMBLY INSTRUCTIONS:

- USE CLEAN GLOVES (PROVIDED) WHEN HANDLING FABRIC**
- ASSEMBLE FRAME BY MATCHING THE SAME LETTERS ON THE ENDS OF THE TUBES (A TO A, B TO B, ETC.) AND MAKE SURE THE GUIDE LINES ARE LINED UP, SEE TOP VIEW FOR SPLICE LOCATIONS
 - INSERT (3) 1/4"-20 HEX DRIVE BOLTS (MTL 10) INTO DESIGNATED HOLES AND TAPE HEADS INTO PLACE SO THEY DO NOT FALL OUT DURING FABRIC FITTING PROCESS
 - THE FABRIC COVER IS MADE TO FIT LIKE A PILLOW CASE, FIND THE CENTER OF THE FABRIC STRIP BETWEEN THE ZIPPERS AND LINE IT UP WITH THE PIECE OF PACKING TAPE ON FRAME SEGMENT C-D
 - MAKE SURE THE THE GROMMETS ON THE COVER ARE ON THE SAME SIDE THE BOLT THREADS ARE PROTRUDING OUT OF THE FRAME TO ENSURE THE COVER ORIENTED PROPERLY
 - START FITTING THE FABRIC COVER ON THE FRAME, PUSH THE BOLTS THROUGH THE GROMMETS AND TIGHTEN THE (3) BARRELS (MTL 20) ONTO THE BOLTS AS THE FABRIC IS ZIPPED. (SEE DETAIL A)
 - ZIP ONE SIDE OF THE COVER UNTIL IT WILL NOT GO ANY FURTHER, THEN SWITCH TO THE OTHER SIDE AND FINISH ZIPPING THE COVER ONTO THE FRAME.
 - USE THE BARRELS AND PROVIDED STAINLESS STEEL WIRE TO HANG THE COVERED FRAME

Hanging Cables

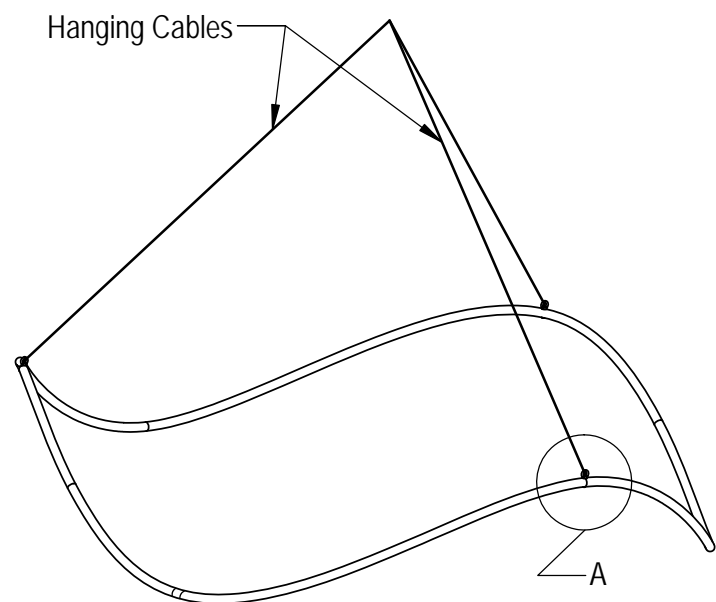

Isometric View
Scale 1 : 32

Hanging Cables

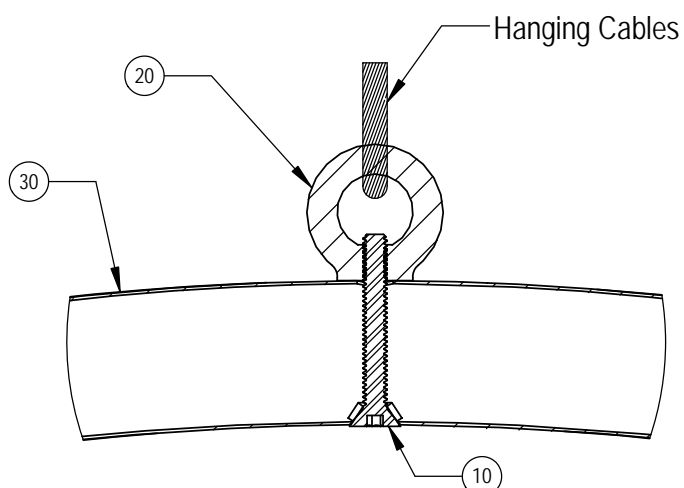

DETAIL A
SCALE 1 : 2

Zipper Wraps
Around This Side

B-B Splice

A-A Splice

Cable Attachment Points

C-C Splice

Packing
Tape
(Assembly
Step 3)

D-D Splice

121 1/2"

Top View
Scale 1 : 16

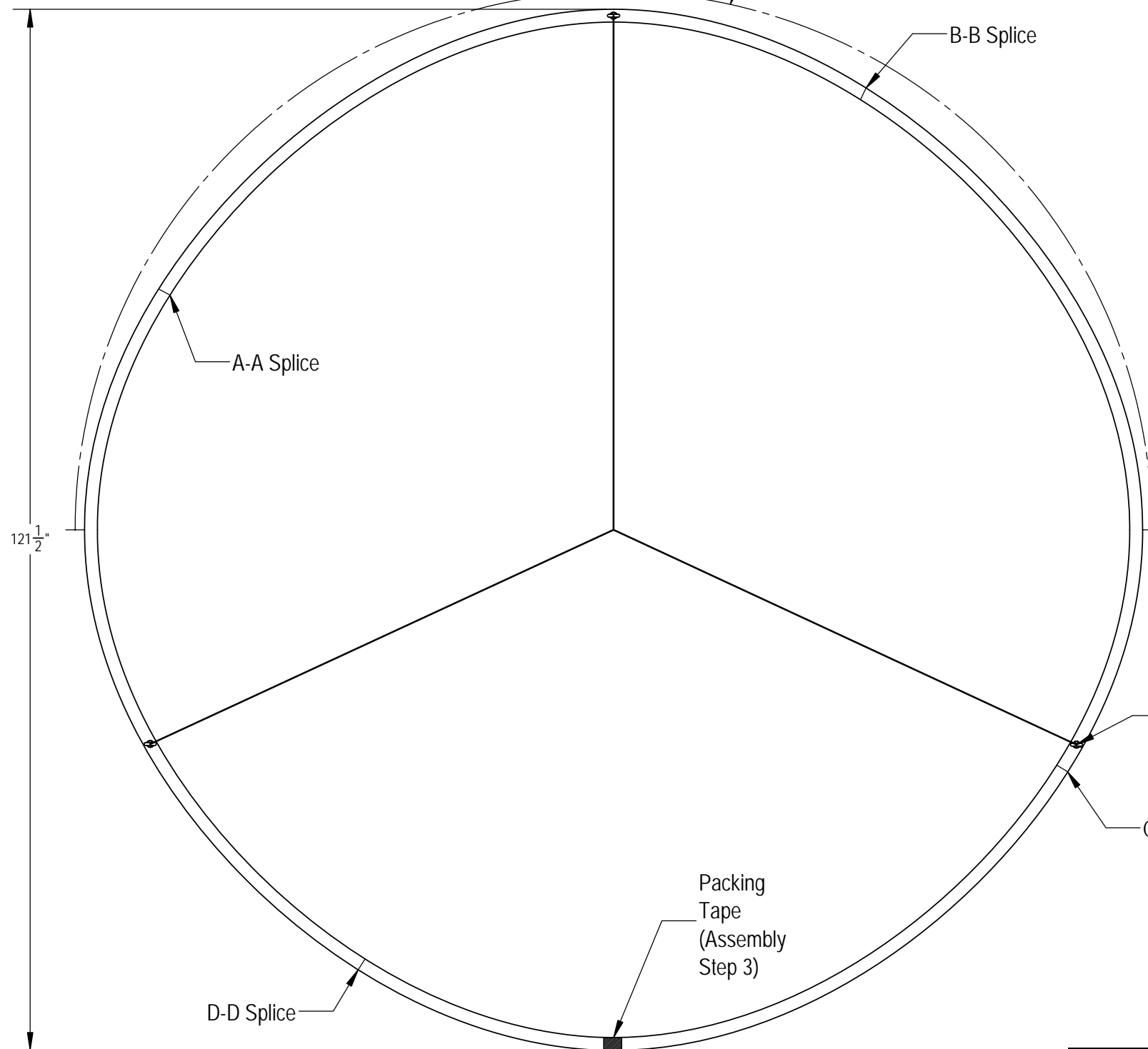

SHEET INDEX

| PAGE | DESCRIPTION | DEPARTMENT |
|-------|-------------------|------------|
| P1.00 | ELEVATION DETAILS | F |

| | | |
|--|---|--|
| RAINIER INDUSTRIES LTD 18375 Olympic Ave. S. Tukwila, WA 98188 www.rainier.com 425-251-1800 Phone | ISO 9001:2000 REGISTERED ISO 14001: EMS - REGISTERED | |
| | TOLERANCES | RAINIER PART # |
| | CUSTOMER | PART DESC. |
| | SALES ORDER | Stratus Cloud |
| .X = ±.5", 1/2" .XX = ±.1", 1/8" .XXX = ±.05", 1/16" | CUSTOMER DRAWING # | Cover Sheet SHEET DESCRIPTION P1.00 SHEET NUMBER |
| Stratus | | |

DELIVERABLES

| DESCRIPTION | QTY |
|---------------|-----|
| Stratus Cloud | 1 |